



Cal. .68



TRAINING FOR ENGAGEMENT



HDX 68

OPERATING
INSTRUCTIONS

WWW.UMAREX.COM

EN	01 Muzzle	DE	01 Mündung	FR	01 Bouche	ES	01 Boca del cañón
	02 Front sight		02 Korn		02 Guidon		02 Punto de mira
	03 Picatinny rail		03 Picatinny Schiene		03 Rails picatinny		03 Riel Picatinny
	04 Rear sight		04 Kimme		04 Cran de mire		04 Alza
	05 Pressure indicator		05 Druckanzeiger		05 Indicateur de pression		05 Tornillo de Quick Piercing
	06 Stock		06 Schaft		06 Crosse		06 Culata
	07 Piercing Button		07 Ansteckknopf		07 Bouton de perçage rapide		07 Botón de pinchado rápido
	08 Stock release		08 Schaftentriegelung		08 Verrou de la crosse		08 Desbloqueo de la culata
	09 Safety		09 Sicherung		09 Sécurité		09 Seguro
	10 Trigger		10 Abzug		10 Détente		10 Gatillo
	11 Loading port		11 Ladeöffnung		11 Ouverture de chargement		11 Orificio de carga
	12 Magazine		12 Magazin		12 Chargeur		12 Cargador
	13 Handguard		13 Vorderschaft		13 Fût		13 Guardamanos
	14 Picatinny rail		14 Picatinny Schiene		14 Rails picatinny		14 Riel Picatinny
IT	01 Bocca	RU	01 Дуло	PL	01 Wylot lufy	TR	01 Namlu ağzı
	02 Mirino		02 Мушка		02 Muszka		02 Arpacık
	03 Slitta Picatinny		03 Направляющая типа Picatinny		03 Szyna Picatinny		03 Picatinny rayı
	04 Tacca di mira		04 Прицельная планка		04 Szczerbina		04 Gez
	05 Indicatore di pressione		05 Индикатор давления		05 Wskaźnik ciśnienia		05 Basınç göstergesi
	06 Calcio		06 Приклад		06 Kolba		06 Kundak
	07 Pulsante a tiro rapido		07 Кнопка для быстрого прокола		07 Przycisk szybkiego przekłuwania		07 Hızlı kapsül delme düğmesi
	08 Sbloccaggio del calcio		08 Фиксатор приклада		08 Odblokowanie rękojeści		08 Kundak kilidi açma
	09 Sicura		09 Предохранитель		09 Bezpiecznik		09 Emniyet
	10 Grilletto		10 Спусковой крючок		10 Spust		10 Tetik
	11 Apertura per il caricatore		11 магазинное оружие		11 Otwór do ładowania pocisku		11 şarj açılış
	12 Caricatore		12 Магазин		12 Magazynek		12 Şarjör
	13 Asta		13 Цевье		13 Wałek przedni		13 Kundak ön kısım
	14 Slitta Picatinny		14 Направляющая типа Picatinny		14 Szyna Picatinny		14 Picatinny rayı

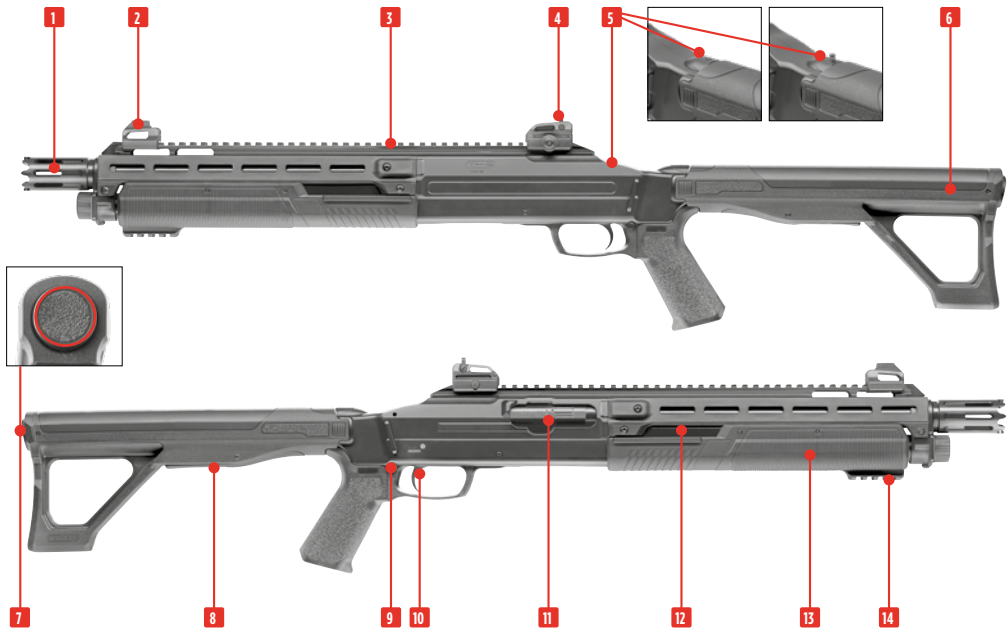

**CAUTION**

Only handle your gun in its safe condition.
Always make sure that the muzzle points in a safe direction.

ACHTUNG

Hantieren Sie nur mit der Waffe, wenn diese gesichert ist.
Achten Sie stets darauf, dass die Mündung in eine sichere Richtung zeigt.

ATTENTION

Ne manipulez l'arme que lorsque la sécurité est enclenchée.
Assurez-vous que la bouche est orientée dans une direction non dangereuse.

ATENCIÓN

Manipule la pistola sólo cuando esté asegurada.
Asegúrese de que la boca apunte siempre en una dirección segura.

**ATTENZIONE**

Accertarsi che la sicura sia inserita prima di iniziare a maneggiare l'arma.
Indirizzate l'arma sempre in una direzione sicura.

ВНИМАНИЕ

Обращайтесь с оружием, только поставив его на предохранитель.
Всегда следите за тем, чтобы ствол оружия был направлен в безопасную сторону.

UWAGA

Proszę posługiwać się wyłącznie zabezpieczoną bronią.
Należy stale kontrolować czy lufa jest skierowana w bezpiecznym kierunku.

DIKKAT

Silahi sadece, emniyetli halde iken elinize alın.
Namlunun her zaman güvenli bir yöne doğrultulmuş olmasına dikkat edin.

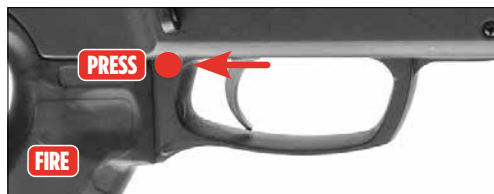
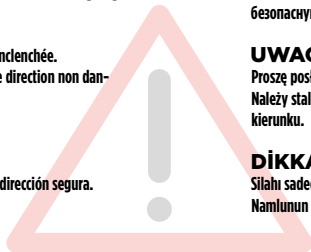



Never use the following balls: (1) with edges, (2) both halves not aligned, (3) used, soiled. Use of unsuitable projectiles will void the warranty.

Verwenden Sie auf keinen Fall folgende Kugeln: (1) mit Grat, (2) versetzte Hälften, (3) gebraucht, verschmutzt. Bei Gebrauch ungeeigneter Geschosse erlischt die Garantie.

N'utilisez jamais des billes BB : (1) avec angles (2) aux moitiés décalées (3) usagées ou sales. L'utilisation de projectiles inappropriés entraîne l'annulation de la garantie.

No utilice en ningún caso bolas: (1) con rebabas, (2) con mitades desplazadas, (3) usadas o sucias. Si se utilizan proyectiles distintos de los apropiados, quedará anulada la garantía.



In ogni caso non usare i seguenti pallini: (1) deformati, (2) con metà sfalsate, (3) usati, sporchi. La garanzia decade in caso di uso di proiettili non adatti.

Ни в коем случае не используйте следующие пули: (1) с зазубринами, (2) со смещенными половинками, (3) использованные или загрязненные пули. При использовании непредназначенных пули, для данного типа оружия зарядов гарантия теряет силу.

Proszę w żadnym wypadku nie używać następujących kulek: (1) z zadziornymi, (2) z przestawionymi połówkami, (3) używanych i zabrudzonych. W przypadku stosowania niewłaściwych pocisków gwarancja wygasa.

Kesinlikle şu tür mermiler kullanmayın: (1) çapaklı, (2) yarısı ofsetli, (3) kullanılmış, kirlî. Uygun olmayan mühimmat kullanılması halinde garanti geçersiz hale gelir.

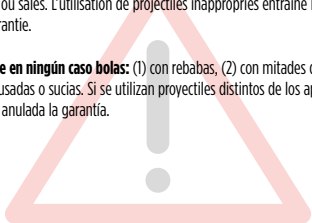

1



2



3



4

LOADING THE MAGAZINE • MAGAZIN LADEN • CHARGEMENT DU CHARGEUR • CHARGER DEL CARGADOR
CARICAMENTO • ЗАРЯЖЕНИЕ МАГАЗИНА • ŁADOWANIE • ŞARJÖRÜN DOLDURULMASI

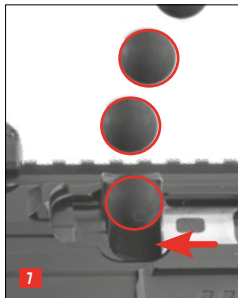
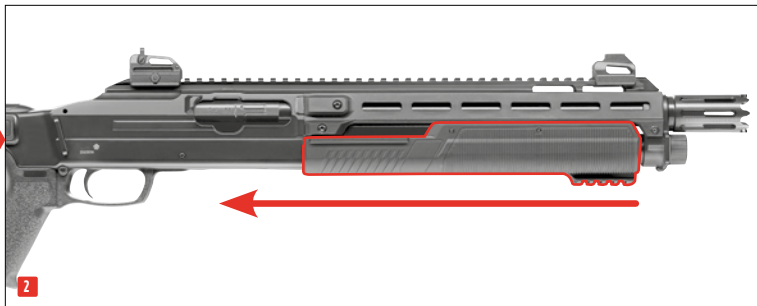

5

UNLOADING • ENTLADEN • DÉCHARGEMENT • DESCARGAR
SCARICO • РАЗРЯЖЕНИЕ • WYŁADUNEK • BOŞALTMA

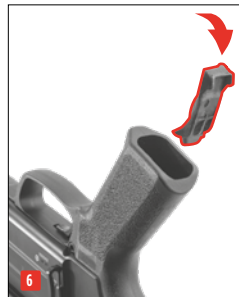
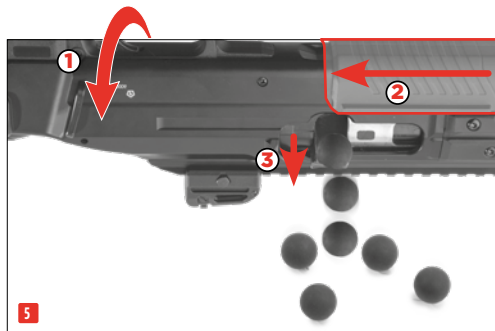
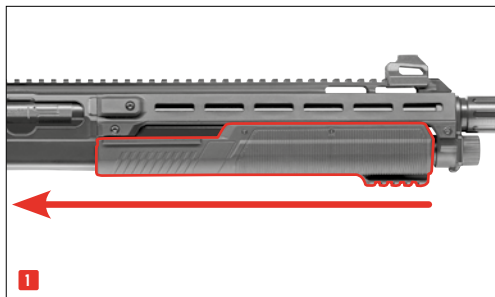

CHANGING THE CO₂ CAPSULE • AUSTAUSCHEN DER CO₂-KAPSEL • REMPLACEMENT DE LA CAPSULE DE CO₂ • SUSTITUCIÓN DE LA CÁPSULA DE CO₂ • SOSTITUZIONE DELLA CAPSULA DI CO₂ • ЗАМЕНА КАПСУЛЫ CO₂ • WYMIANA KAPSUŁY CO₂ • CO₂ KAPSULÜNÜN DEĞİŞTİRİLMESİ

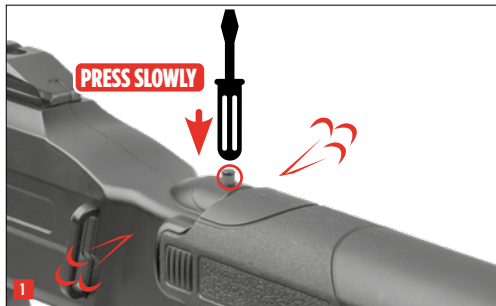

INSERT CO₂ CAPSULE • CO₂-KAPSEL EINSETZEN • INSÉRER LA CAPSULE DE CO₂ • INSERTAR LA CÁPSULA DE CO₂ • INSERIRE LA CAPSULA DI CO₂ • ВСТАВЬТЕ КАПСУЛУ С CO₂ • WŁOŻYC KAPSUŁĘ CO₂ • CO₂ KAPSULÜ YERLEŞTİRİN



- Only use 12 / 88 g CO₂ capsules.
- For storage remove gas capsules.
- There may be a minor discharge of gas when you remove the gas capsules.

Make sure that your hands do not come into contact with discharged CO₂ gas. This may cause freezing of the skin. Do not expose the CO₂ cartridge to excessive heat and do not store it at temperatures exceeding 54 °C. Always adhere to the warnings and safety instructions of the manufacturer on the gas cartridge in respect to handling and storage of a CO₂ gas container.

- Verwenden Sie nur 12 / 88 g CO₂-Kapseln.
- Für die Lagerung der Waffe CO₂-Kapseln entnehmen!
- Beim Herausnehmen der CO₂-Kapsel kann es zu einem leichten Austritt von CO₂ kommen.

Achten Sie darauf, dass Ihre Hände nicht mit austretendem CO₂-Gas in Berührung kommen. Bei Kontakt mit der Hand kann es zu Erfrierungen kommen. Setzen Sie die CO₂-Kapsel keiner großen Hitze aus und lagern Sie diese Behälter nicht bei Temperaturen über 54 °C. Halten Sie sich immer an die auf der CO₂-Kapsel aufgedruckten Warn- und Sicherheitshinweise des Herstellers bezüglich Umgang und Lagerung der CO₂-Kapsel.

- Utilisez seulement des capsules de CO₂ de 12 / 88 g.
- Retirez la capsule de CO₂ avant de ranger l'arme.
- En retirant la capsule de CO₂, il est possible qu'une petite quantité de gaz s'échappe.

Veillez à ce que vos mains n'entrent pas en contact avec le gaz CO₂ qui s'échappe. Le contact avec la peau peut entraîner des gelures. Ne soumettez pas les capsules de CO₂ à une chaleur trop importante et ne les stockez pas à des températures supérieures à 54 °C. Respectez toujours les consignes de sécurité et avertissements figurant sur la capsule de CO₂ relatifs à l'utilisation et au stockage de capsules de CO₂.

- Utilice únicamente cápsulas CO₂ de 12 g / 88 g.
 - Para guardar el arma extraiga los cápsulas de CO₂.
 - Al extraer el cápsula de CO₂, es posible que se escape una pequeña cantidad de gas.
- Procure que sus manos no entren en contacto con el CO₂ en caso de fuga, ya que un eventual contacto con la piel puede causar congelación. No exponga el cápsula de CO₂ a un calor excesivo ni lo guarde a temperaturas superiores a los 54 °C. Observe siempre las advertencias e instrucciones de seguridad del fabricante sobre la manipulación y el almacenamiento del cápsula de aire comprimido.



- Usare solo le capsula CO₂ 12/88 g.
- Prima di riporre l'arma, togliere la capsula CO₂!
- Durante l'estrazione della capsula CO₂ può verificarsi una leggera fuoriuscita di gas CO₂.

Raccomandiamo di prestare attenzione affinché le mani non vengano a contatto con il gas CO₂ che fuoriesce dall'arma. L'eventuale contatto con la pelle potrebbe provocare congelamenti. Non esporre le capsula CO₂ a fonti di calore eccessivo e conservarle in contenitori a temperature non superiori a 54 °C. Osservare sempre le avvertenze e le norme di sicurezza del produttore stampate sulla capsula relative all'utilizzo e alla conservazione delle capsula CO₂.

- Применять только баллончики с 12 / 88 г CO₂.
 - При постановке оружия на хранение вынимать баллончик CO₂!
 - При извлечении баллончика CO₂ может произойти незначительная утечка CO₂.
- Обратите внимание на то, чтобы Ваши руки не соприкасались с выходящим газом CO₂. При контакте с кожей может наступить обморожение. Берегите баллончик с газом CO₂ от перегрева и не храните его при температуре выше 54 °C. Всегда соблюдайте напечатанные производителем на баллончике CO₂ указания по мерам безопасности в отношении обращения и хранения баллончика CO₂.

- Proszę używać tylko naboju 12 / 88 g CO₂.
 - Broń należy przechowywać bez naboju CO₂!
 - Przy wyciąganiu naboju CO₂ może dojść do małego wycieku dwutlenku węgla.
- Proszę chronić ręce przed zetknięciem z wyciekami dwutlenku węgla. W kontakcie CO₂ ze skórą może dojść do odmrożeń. Naboju CO₂ nie należy wystawiać go na działanie wysokiej temperatury, proszę przechowywać go poniżej w temp 54°C. Proszę przestrzegać wskazówek producenta dot. zasad bezpieczeństwa przy obsłudze i przechowywaniu naboju CO₂. Informacje te znajdują Państwo na naboju.

- Sadece 12 / 88 g*lık CO₂ kapsülleri kullanın.
- Silahı saklamadan önce CO₂ kapsülünü çıkarın!
- CO₂ kapsülünü çıkarırken biraz CO₂ sızabilir.

Ellerinizi silahtan çıkan CO₂ gazıyla temas etmemesine dikkat edin. Elinizle temas halinde deride donmalar oluşabilir. CO₂ kapsülünü aşırı sıcak koşullara maruz bırakmayın ve bu kapları 54 °C'den daha sıcak ortamlarda saklamayın. CO₂ kapsülü üzerinde yer alan, CO₂ kapsülünün kullanımı ve saklanmasıyla ilgili basılı üretici uyarı ve güvenlik bilgilerine daima uyun.

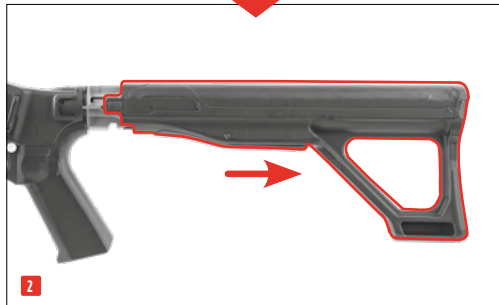

2.4745 + 2.4746



2.4747 - 2 x 12g Adapter



2.4747 · 1 x 88g Capsules

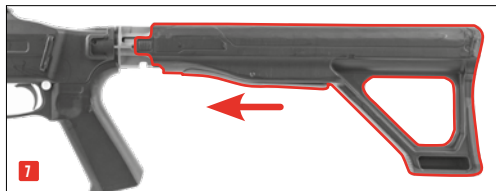
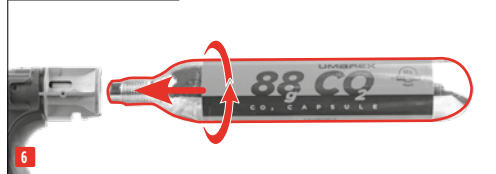

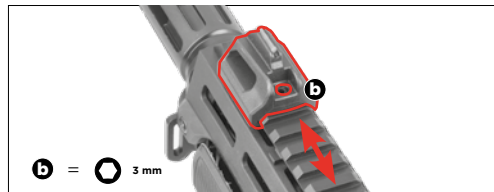
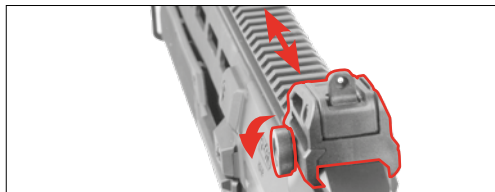
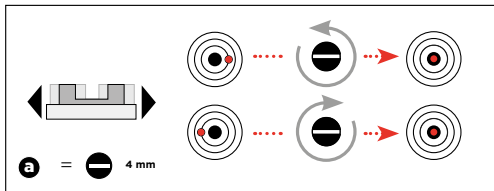
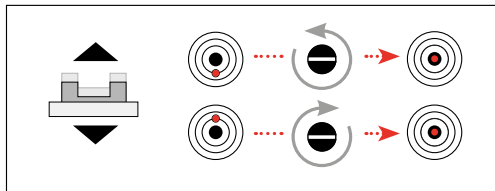
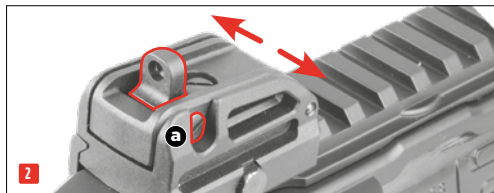
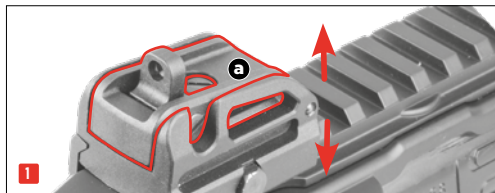

**PROBLEMS • PROBLEME
 DYSFONCTIONNEMENTS • PROBLEMAS
 PROBLEMI • ПРОБЛЕМЫ
 PROBLEMY • PROBLEMLER**
**POSSIBLE CAUSES • MÖGLICHE GRÜNDE
 CAUSES POSSIBLES • POSIBLES CAUSAS
 POSSIBILI CAUSE • ВОЗМОЖНЫЕ ПРИЧИНЫ
 MOŻLIWE PRZYCZYNY • OLASI NEDENLER**

PROBLEMS • PROBLEME DYSFONCTIONNEMENTS • PROBLEMAS PROBLEMI • ПРОБЛЕМЫ PROBLEMY • PROBLEMLER	POSSIBLE CAUSES • MÖGLICHE GRÜNDE CAUSES POSSIBLES • POSIBLES CAUSAS POSSIBILI CAUSE • ВОЗМОЖНЫЕ ПРИЧИНЫ MOŻLIWE PRZYCZYNY • OLASI NEDENLER		
	Safety activated Waffe gesichert Sécurité de l'arme enclenchée Seguro activado Sicura attivata Оружие стоит на предохранителе Broń zabezpieczona Silah emniyette	CO ₂ capsule not pierced CO ₂ -Kapsel nicht angestoßen Capsule de CO ₂ non percée rcée Cápsula de CO ₂ sin perforar Capsula a CO ₂ non bucata Отсутствие накола баллончика с CO ₂ Nabój CO ₂ nie przekłuty CO ₂ kapsülü delinmemiş	Dirty barrel Lauf verschmutzt Canon encrassé Cañón sucio Canna sporca internamente Ствол загрязнен Zanieczyszczona lufa Namlu kirli
Gun does not shoot • Waffe schießt nicht l'arme ne tire pas • El arma no dispara L'arma non spara • Плохие показатели стрельбы złe efekty strzelania • Kötü atış performansı	○	○	○
Faulty shooting direction • Schlechte Schussleistung Mauvaise performance de tir • Potencia de disparo deficiente Scarsa precisione • Оружие не стреляет broń nie strzela • Silah atış almıyor			○
Low shooting speed • Geringe Schussgeschwindigkeit Faible vitesse du projectile • Escasa velocidad de disparo Velocità ridotta del proiettile • Слабая скорость полета пули niska prędkość śrutu • Merinin hızı düşük			○

CO₂ capsule / Magazine empty
CO₂ -Kapsel / Magazin leer
Capsule de CO₂ / Chargeur vide
Capsula a CO₂ / Caricatore vuoto
Cápsula de CO₂ / Cargador vacío
Балончик с CO₂ / Магазин пустой
Nabój CO₂ / Magazynek pusty
CO₂ kapsülü / şarjör boş

Extreme temperatures
Extreme Temperaturen
Températures extrêmes
Temperaturas extremas
Temperature estreme
Экстремальные температуры
Ekstremalne temperatur
Aşırı sıcak/soğuk

Wrong ammunition
Falsche Munition
Mauvaises munitions
Munición errónea
Munizione sbagliata
Боеприпасы не подходят
Zła amunicja
Yanlış mühimmat

Ammunition badly loaded
Munition falsch geladen
Munitions mal chargées
Munición mal cargada
Munizione caricata in maniera errata
Боеприпасы неправильно снаряжены
Niepoprawnie załadowana amunicja
Mühimmat yanlış doldurulmuş

Sight not properly adjusted
Visierung nicht richtig eingestellt
Dispositif de visée mal réglé
La mira no está bien ajustada
Dispositivo di mira non regolato
correttamente
Неправильно установлен прицел
Błędnie ustawiony celownik
Nişangâh doğru ayarlanmamış



System / Power Source • System / Antrieb • Système / Source de Propulsion
 Sistema / Propulsión • Sistema / Alimentazione • Система/Источник энергии
 System / Zródło • Sistem / Enerji kaynağı

CO₂ Gun • CO₂-Gewehr • Fusil CO₂ • Rifle de CO₂
 Fucile a CO₂ • винтовка CO₂ • Karabin CO₂ • CO₂ tüfeği

Caliber / Ammo • Kaliber / Munition • Calibre / Munitions • Kaliber / Munitión
 Calibro / Munizioni • Калибр • Kaliber / Amunición • Kalibre / Mühimmat

.68

Capacity • Kapazität • Capacité • Capacidad
 Capacità • Емкость магазина • Pojemność magazynka • Şarjör kapasitesi

16

Energy / Velocity • Energie / Geschwindigkeit • Énergie / Vitesse
 Energia / Velocidad • Energia / Velocità • Энергия / Скорость полета пули
 Energia / Prędkość • Enerji / Mermi hızı

2.4745:
<7,5 J: 70 m/s



2.4746:
16 J: 105 m/s

2.4747:
40 J: 165 m/s

Stock • Schaft • Crosse • Culata • Calcio • Приклад • Kolba • Renk

synthetic • Kunststoff • synthétique • sintético • sintetico • Пластик • tworzywo sztuczne • plastik

Safety • Sicherung • Sécurité • Seguro
 Sikura • предохранитель • Bezpiecznik • Emniyet

manual • manuel • manuel • manual • manuale • ручной • manualny • manuel

Barrel length • Lauflänge • Logueur canon • Longitud del cañón
 Lunghezza canna • Длина ствола • Długość lufy • Namlu uzunluğ

366 mm

366 mm

366 mm

Dangerous area up to • Max. Gefahrenbereich bis zu • Zone de danger
 s'étendant • Distancia máxima de peligro • Distanza massima di pericolo • Макс.
 протяженность опасной зоны • Maks. obszar zagrożenia do • Maksimum
 tehlike alanı

125 m

160 m

200 m

Weight • Gewicht • Poids • Peso • Peso • Вес • Waga • Ağırlık

3055 g

3055 g

2850 g

Overall length • Gesamtlänge • Longueur • Longitud
 Lunghezza • Длина • Długość całkowita • Toplam uzunluk

896 mm

2.4745

ITEM:	ITEM NO:	INCLUDES FOLLOWING PARTS:	ITEM:	ITEM NO:	INCLUDES FOLLOWING PARTS:
BACK STOCK ASSY	81.10.0001	1E	BB FOLLOWER ASSY	81.60.0004	1B
IMPACT SEAT	81.10.0002	E-03	VALVE CASING ASSY	81.60.0005	1D
STOCK COVER	81.10.0003	E-04	VALVE CHAMBER ASSY	81.60.0006	7
IMPACT SEAT SPRING	81.10.0004	E-08	CHAMBER ASSY	81.60.0007	8B
SCREW 5X16	81.20.0001	1-18	FRONT SIGHT ASSY	81.70.0001	1CM
SPEED LOADER SEAT	81.20.0002	1-25	SIGHT SEAT ASSY	81.70.0002	1DDM
SPEED LOADER	81.20.0003	1-26			
TRIGGER	81.20.0004	A-03			
TRIGGER CONNECTOR	81.20.0005	A-04			
BB STOPPER CATCH	81.50.0001	A-06			
BB STOPPER	81.50.0002	A-07			
POINT	81.20.0006	A-08			
TRIGGER CONNECTOR SPRING	81.20.0007	A-12			
BB STOPPER CATCH SPRING	81.50.0003	A-13			
POINT SPRING	81.20.0008	A-14			
BB STOPPER SPRING	81.50.0004	A-16			
TRIGGER RELEASE SPRING	81.20.0009	A-17			
TRIGGER RELEASE PARTS	81.20.0010	A-24			
TRIGGER CONNECTOR ASSY	81.20.0011	1F			
SCREW 2X6	81.30.0001	1-13			
SCREW 3X10	81.30.0002	1-14			
SCREW 4X6.5	81.30.0003	1-15			
SCREW 4X42	81.30.0004	1-16			
SCREW 3X10	81.30.0005	1-17			
RECOIL SPRING	81.40.0001	1-24			
MAGAZINE SPRING	81.60.0001	1-22			
O-RING 20X1.6	81.60.0002	1-23			
VALVE CASING SPRING	81.60.0003	A-15			
BB STOPPER	81.50.0005	A-21			

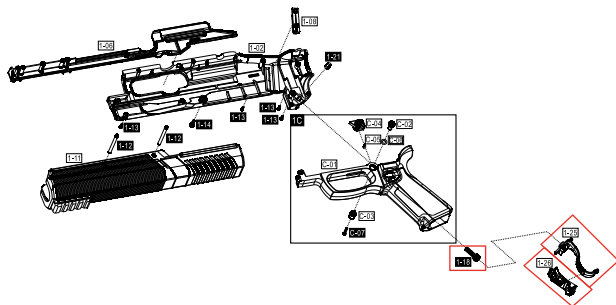
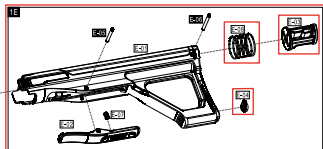
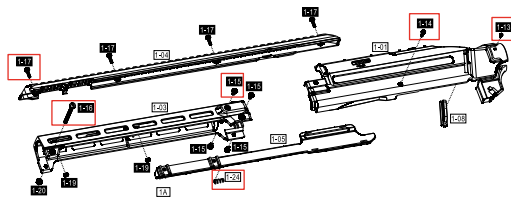
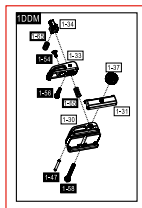
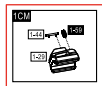

2.4746

ITEM:	ITEM NO:	INCLUDES FOLLOWING PARTS:	ITEM:	ITEM NO:	INCLUDES FOLLOWING PARTS:
BACK STOCK ASSY	81.10.0001	1E	BB FOLLOWER ASSY	81.60.0004	1B
IMPACT SEAT	81.10.0002	E-03	VALVE CASING ASSY	81.60.0005	1D
STOCK COVER	81.10.0003	E-04	VALVE CHAMBER ASSY	81.60.0006	7
IMPACT SEAT SPRING	81.10.0004	E-08	CHAMBER ASSY	81.60.0007	8B
SCREW 5X16	81.20.0001	1-18	FRONT SIGHT ASSY	81.70.0001	1CM
SPEED LOADER SEAT	81.20.0002	1-25	SIGHT SEAT ASSY	81.70.0002	1DDM
SPEED LOADER	81.20.0003	1-26			
TRIGGER	81.20.0004	A-03			
TRIGGER CONNECTOR	81.20.0005	A-04			
BB STOPPER CATCH	81.50.0001	A-06			
BB STOPPER	81.50.0002	A-07			
POINT	81.20.0006	A-08			
TRIGGER CONNECTOR SPRING	81.20.0007	A-12			
BB STOPPER CATCH SPRING	81.50.0003	A-13			
POINT SPRING	81.20.0008	A-14			
BB STOPPER SPRING	81.50.0004	A-16			
TRIGGER RELEASE SPRING	81.20.0009	A-17			
TRIGGER RELEASE PARTS	81.20.0010	A-24			
TRIGGER CONNECTOR ASSY	81.20.0011	1F			
SCREW 2X6	81.30.0001	1-13			
SCREW 3X10	81.30.0002	1-14			
SCREW 4X6.5	81.30.0003	1-15			
SCREW 4X42	81.30.0004	1-16			
SCREW 3X10	81.30.0005	1-17			
RECOIL SPRING	81.40.0001	1-24			
MAGAZINE SPRING	81.60.0001	1-22			
O-RING 20X1.6	81.60.0002	1-23			
VALVE CASING SPRING	81.60.0003	A-15			
BB STOPPER	81.50.0005	A-21			

2.4746

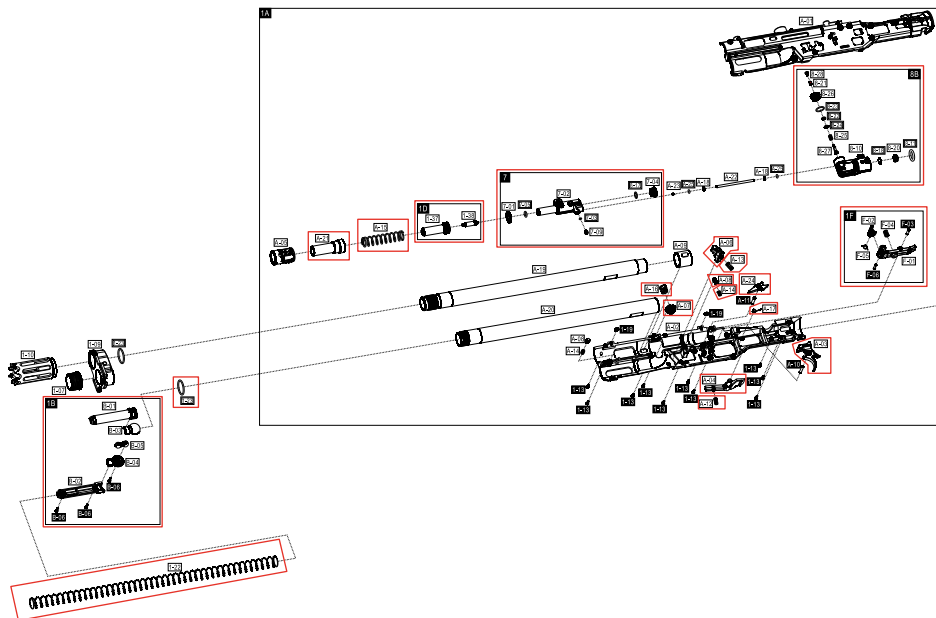

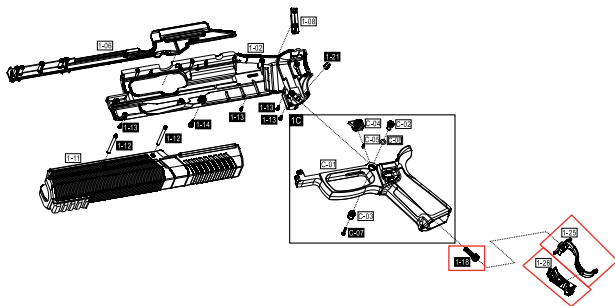
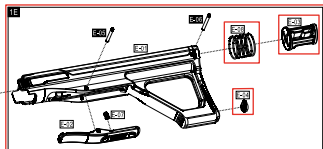
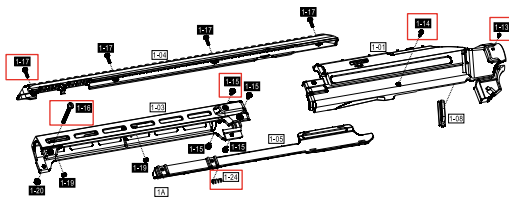
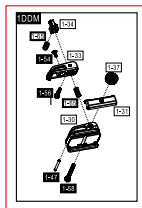
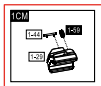

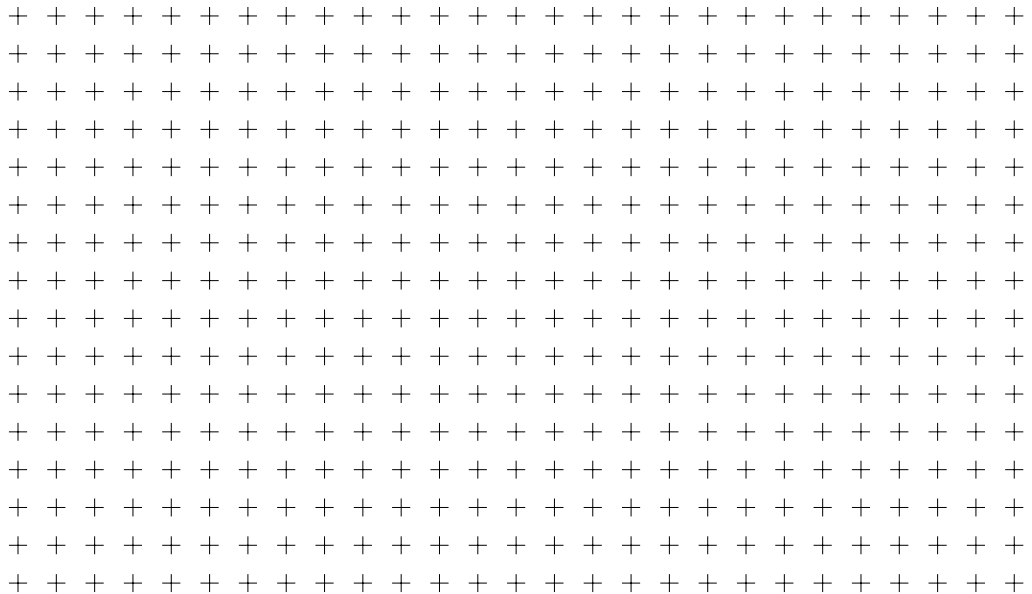

2.4747

ITEM:	ITEM NO:	INCLUDES FOLLOWING PARTS:	ITEM:	ITEM NO:	INCLUDES FOLLOWING PARTS:
BACK STOCK ASSY	81.10.0001	1E	BB FOLLOWER ASSY	81.60.0004	1B
IMPACT SEAT	81.10.0002	E-03	VALVE CASING ASSY	81.60.0005	1D
STOCK COVER	81.10.0003	E-04	VALVE CHAMBER ASSY	81.60.0006	7
IMPACT SEAT SPRING	81.10.0004	E-08	CHAMBER ASSY	81.60.0007	8B
SCREW 5X16	81.20.0001	1-18	FRONT SIGHT ASSY	81.70.0001	1CM
SPEED LOADER SEAT	81.20.0002	1-25	SIGHT SEAT ASSY	81.70.0002	1DDM
SPEED LOADER	81.20.0003	1-26			
TRIGGER	81.20.0004	A-03			
TRIGGER CONNECTOR	81.20.0005	A-04			
BB STOPPER CATCH	81.50.0001	A-06			
BB STOPPER	81.50.0002	A-07			
POINT	81.20.0006	A-08			
TRIGGER CONNECTOR SPRING	81.20.0007	A-12			
BB STOPPER CATCH SPRING	81.50.0003	A-13			
POINT SPRING	81.20.0008	A-14			
BB STOPPER SPRING	81.50.0004	A-16			
TRIGGER RELEASE SPRING	81.20.0009	A-17			
TRIGGER RELEASE PARTS	81.20.0010	A-24			
TRIGGER CONNECTOR ASSY	81.20.0011	1F			
SCREW 2X6	81.30.0001	1-13			
SCREW 3X10	81.30.0002	1-14			
SCREW 4X6.5	81.30.0003	1-15			
SCREW 4X42	81.30.0004	1-16			
SCREW 3X10	81.30.0005	1-17			
RECOIL SPRING	81.40.0001	1-24			
MAGAZINE SPRING	81.60.0001	1-22			
O-RING 20X1.6	81.60.0002	1-23			
VALVE CASING SPRING	81.60.0003	A-15			
BB STOPPER	81.50.0005	A-21			

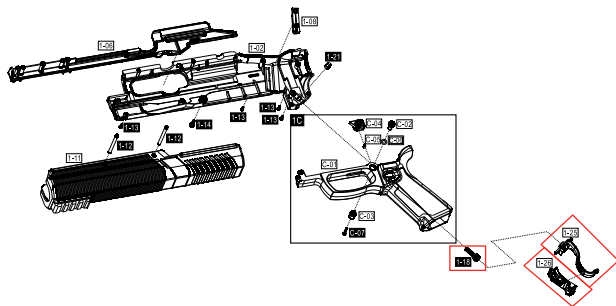
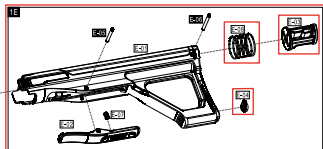
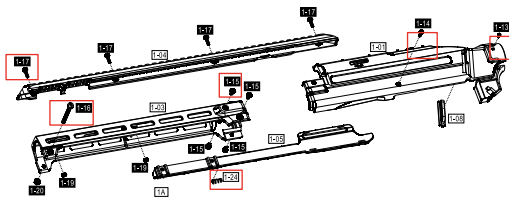
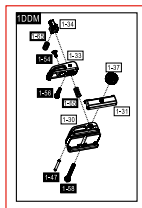
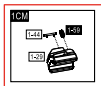

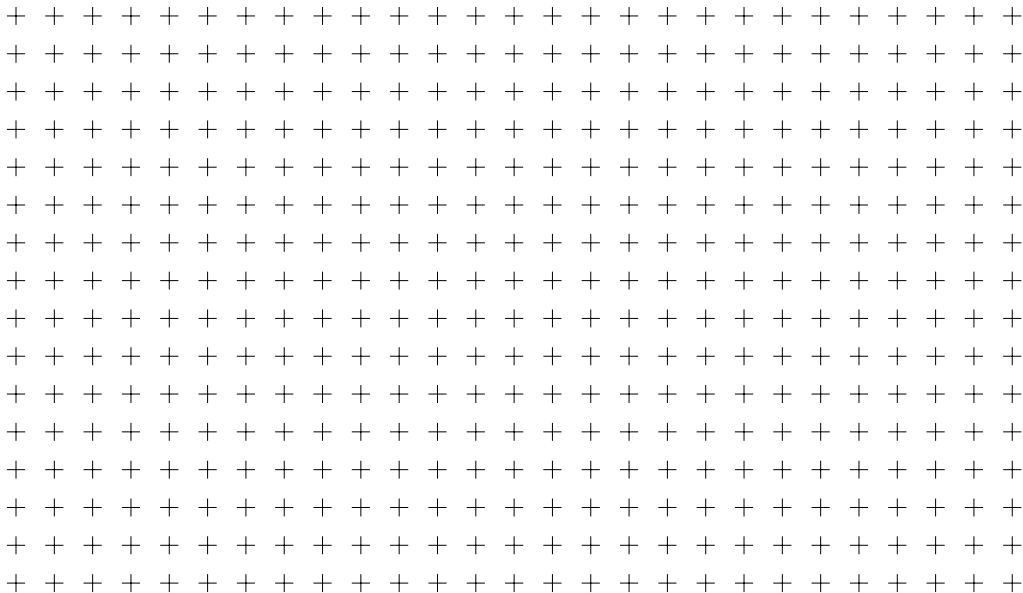



TRAINING FOR ENGAGEMENT

EN We reserve the right to make color and design changes and technical improvements. No responsibility is accepted for printing errors or incorrect information. **DE** Änderungen in Farbe und Design sowie technische Verbesserungen, Druckfehler und Irrtum vorbehalten. Alle Angaben ohne Gewähr. **FR** Sauf modifications de la couleur et du design ainsi que des améliorations techniques, erreurs d'impression et erreur. Toutes les données sont fournies sans garantie. **ES** Salvo modificaciones de color y de diseño así como mejoramientos técnicos, erratas y error. Todos los datos sin garantía. **IT** Con riserva di modifiché di colore e di design, di miglioramenti tecnici, di errori di stampa e di sbagli. Tutte le informazioni senza garanzia. **RU** Изменения цвета и дизайна, а также технические улучшения, опечатки и ошибки не исключены. Мы не гарантируем точность сведений. **PL** Zastrzegamy sobie prawo do pomyłek, błędów w druku, zmian koloru i designu, jak również do wprowadzania technicznych ulepszeń. Wszystkie informacje bez gwarancji. **TR** Renk, tasarım ve teknik değişiklikler yapma hakkı saklıdır. Baskı hatalarından ya da hatalı bilgilerden dolayı yasal sorumluluk kabul edilmez. Bilgiler için garanti verilmez.

UMAREX GmbH & Co. KG • Donnerfeld 2 • 59757 Arnsberg • Germany • service@umarex.de

WWW.UMAREX.COM

Covers models:

2.4745

2.4746

2.4747